



**FUJI**  
**ELECTRIC**

**SPLIT TYPE AIR  
CONDITIONER (50Hz)**

**DUCT** type

# SERVICE MANUAL

Models	Indoor unit	Outdoor unit
	RD-9AA	ROD-9AA
	RD-9RA	ROD-9RA

## CONTENTS

SPECIFICATIONS .....	1
OUTLINE AND DIMENSIONS.....	2
CIRCUIT DIAGRAM .....	3
INDOOR P. C. BOARD CIRCUIT DIAGRAM .....	5
OUTDOOR P. C. BOARD CIRCUIT DIAGRAM .....	7
INDOOR P. C. BOARD LAYOUTS .....	8
OUTDOOR P. C. BOARD LAYOUTS .....	10
REFRIGERANT SYSTEM DIAGRAM .....	11
DISASSEMBLY ILLUSTRATION .....	12
PARTS LIST .....	22



**Большая библиотека технической документации**

<https://splitsystema48.ru/instrukcii-po-ekspluatácii-kondicionerov.html>

**каталоги, инструкции, сервисные мануалы, схемы.**

# SPECIFICATIONS

INDOOR UNIT		RD-9AA	RD-9RA
OUTDOOR UNIT		ROD-9AA	ROD-9RA
COOLING CAPACITY	(kW)	2.70 - 2.80	2.60 - 2.70
HEATING CAPACITY	(kW)	—	3.00 - 3.10

## ELECTRICAL DATA

POWER SOURCE	(V)	220 - 240		
FREQUENCY	(Hz)	50		
RUNNING CURRENT	(A)	COOLING	4.3 - 4.2	4.1 - 3.9
		HEATING	—	4.1 - 3.9
INPUT WATTS	(kW)	COOLING	0.93 - 0.97	0.87 - 0.92
		HEATING	—	0.87 - 0.92
EER	(kW/kW)	COOLING	2.90 - 2.89	2.99 - 2.94
		HEATING	—	3.45 - 3.37
MOISTURE REMOVAL	(ℓ/hr)	0.8		
AIR CIRCULATION-Hi	(m <sup>3</sup> /hr)	420		

## COMPRESSOR

TYPE	Hermetic type, Permanent split condenser, 2 pole, Single phase, Induction motor
CODE	GRG103CA

## FAN MOTOR

	RD-9AA	RD-9RA	ROD-9AA	ROD-9RA
TYPE	MFA-09FTT		MFA-14VTB	MFB-09FT
POWER SOURCE	(V)	220 - 240		
HI-SPEED	(r.p.m.)	960	740	740
MED-SPEED	(r.p.m.)	880	—	—
LO-SPEED	(r.p.m.)	810	—	440

## DIMENSIONS

H x W x D	(mm)	217 x 663 x 595	530 x 750 x 250
-----------	------	-----------------	-----------------

## WEIGHTS

GROSS / NET	(kg)	22 / 18	32 / 30	36 / 34
-------------	------	---------	---------	---------

## REFRIGERANT CHARGE

PIPE LENGTH		15 m or less
FULL CHARGE AMOUNT	RD-9AA	920 g (32.5 oz.)
	RD-9RA	950 g (33.5 oz.)

- Note :
- Since this is a chargeless air conditioner, if the piping length is 15 m (49 ft.) or less, additional charging is unnecessary.
  - The above list shows values at the external static pressure of 0 mmAg (0 Pa).

# OUTLINE AND DIMENSIONS

[INDOOR UNIT]

Unit : mm

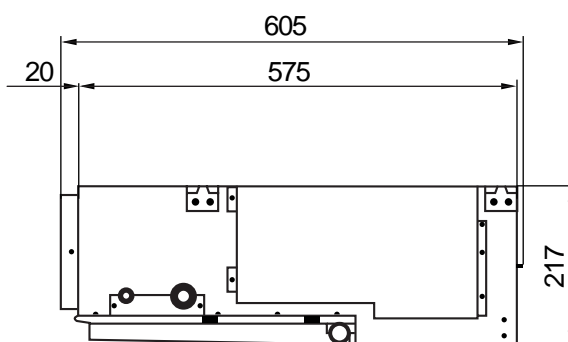
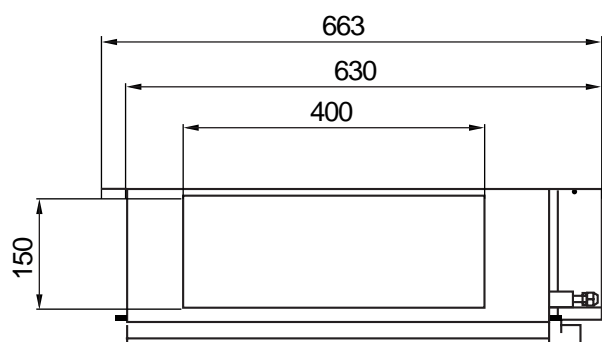
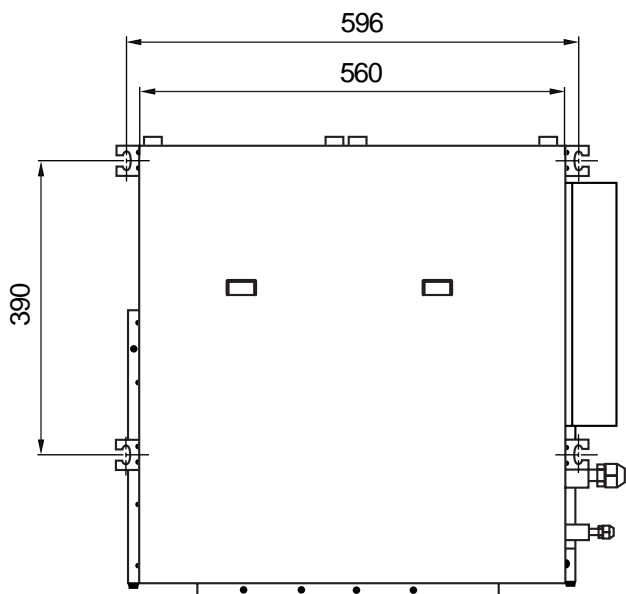

[OUTDOOR UNIT]

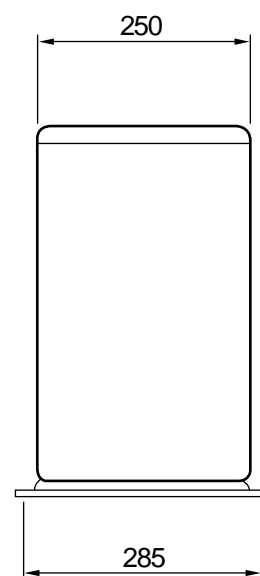
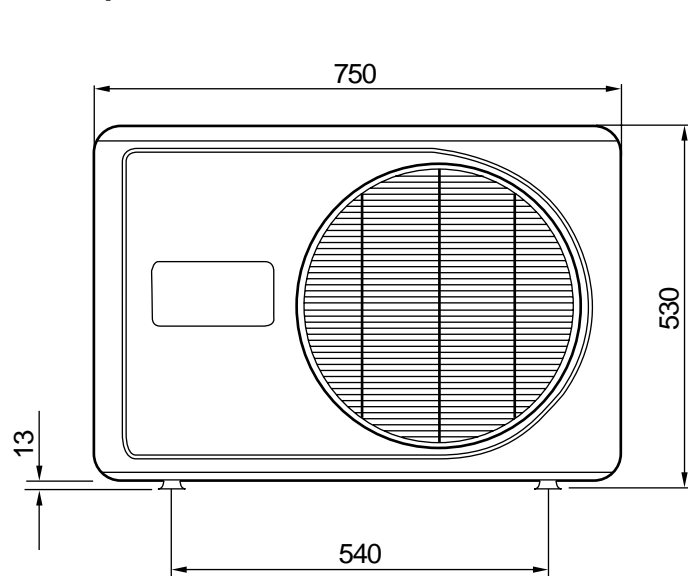

# REFRIGERANT SYSTEM DIAGRAM

Models : RD-9AA / ROD-9AA

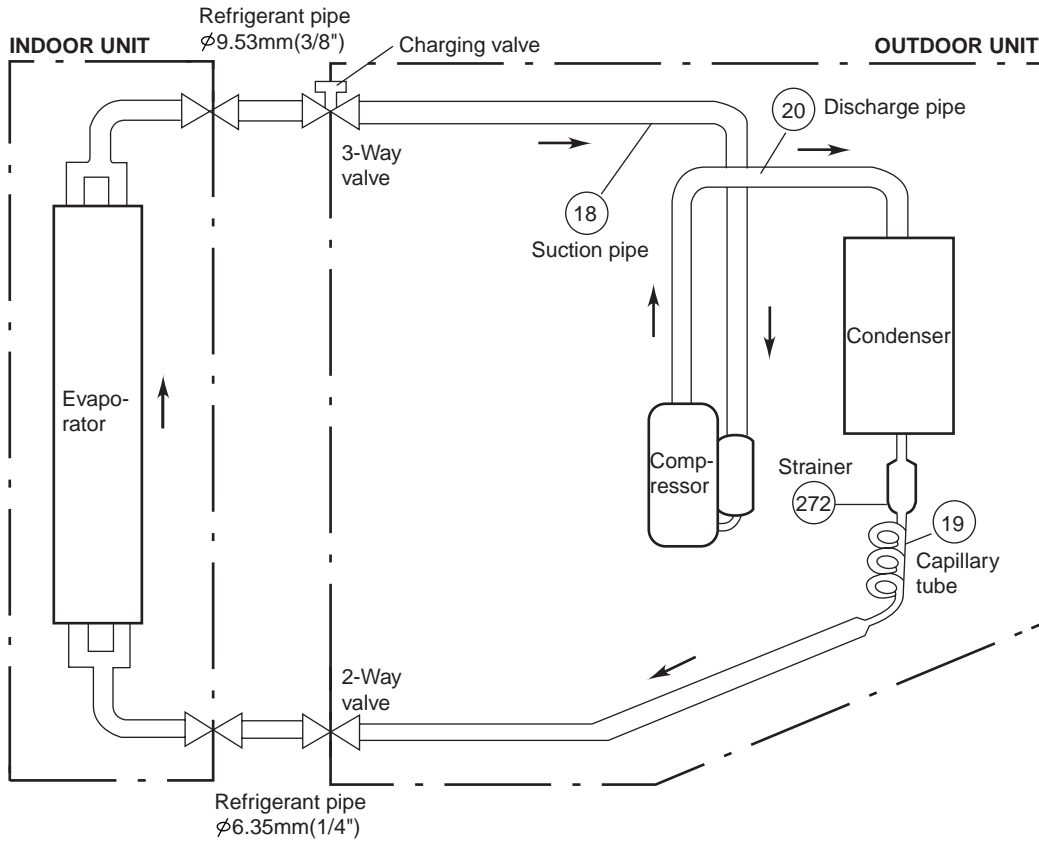

Models : RD-9RA / ROD-9RA

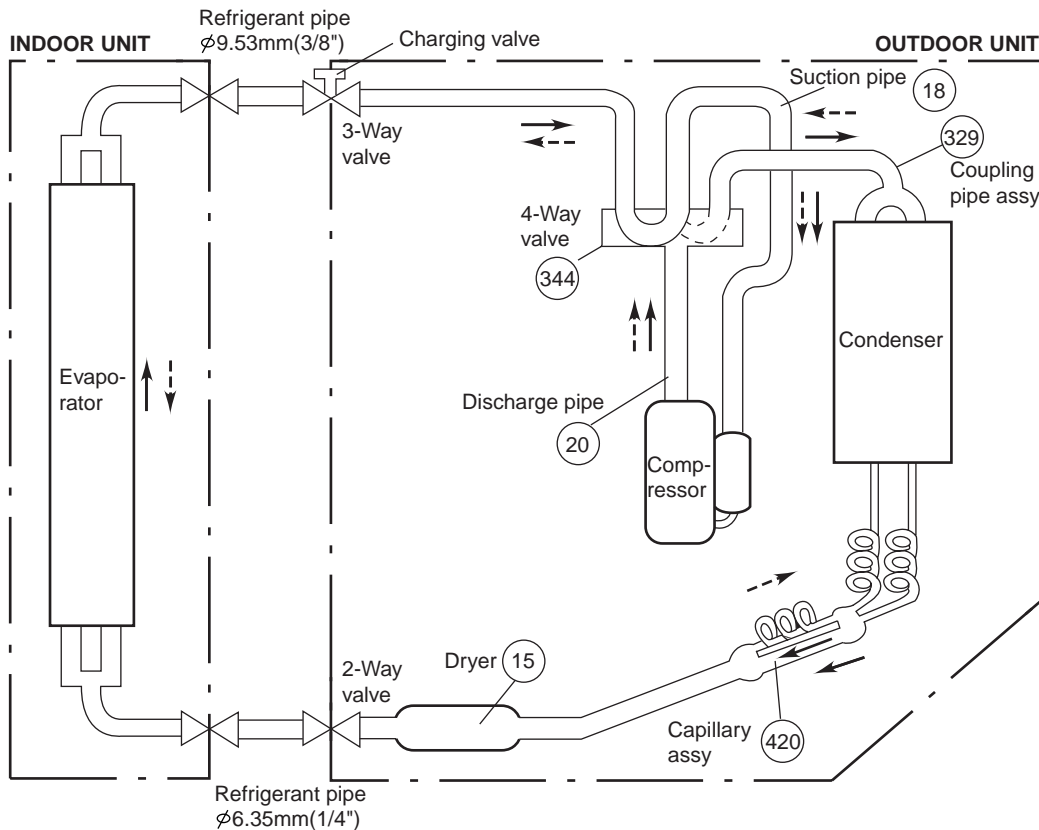

Cooling  $\longrightarrow$

Heating  $\dashrightarrow$

 : Flare coupling

# CIRCUIT DIAGRAM

Models : RD-9AA / ROD-9AA

## INDOOR UNIT

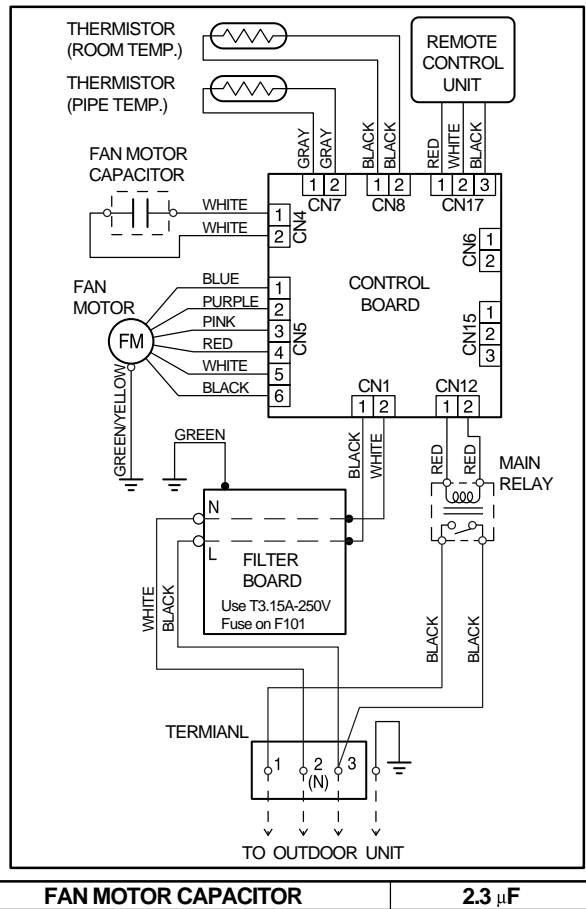

**FAN MOTOR CAPACITOR**

**2.3  $\mu$ F**

## OUTDOOR UNIT

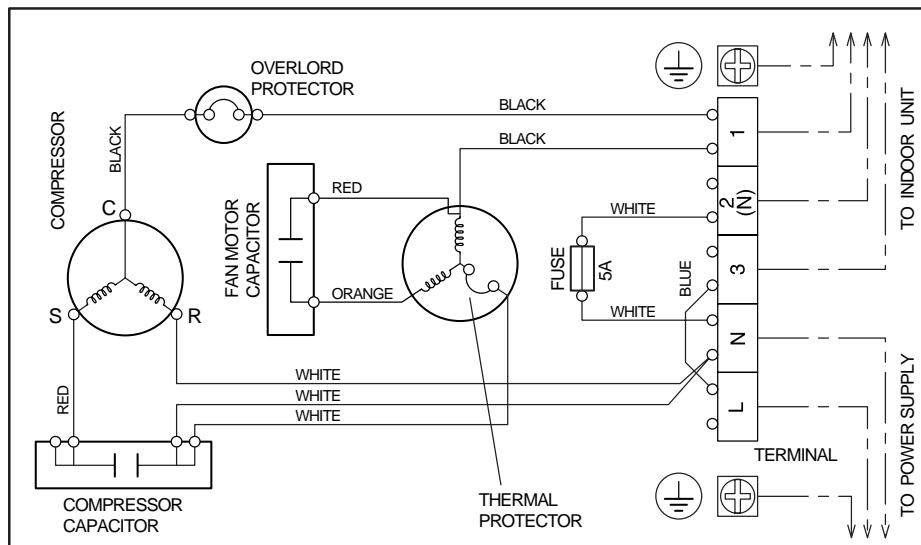

**FAN MOTOR CAPACITOR**

**1.6  $\mu$ F**

**COMPRESSOR CAPACITOR**

**35  $\mu$ F**

Models : RD-9RA / ROD-9RA

INDOOR UNIT

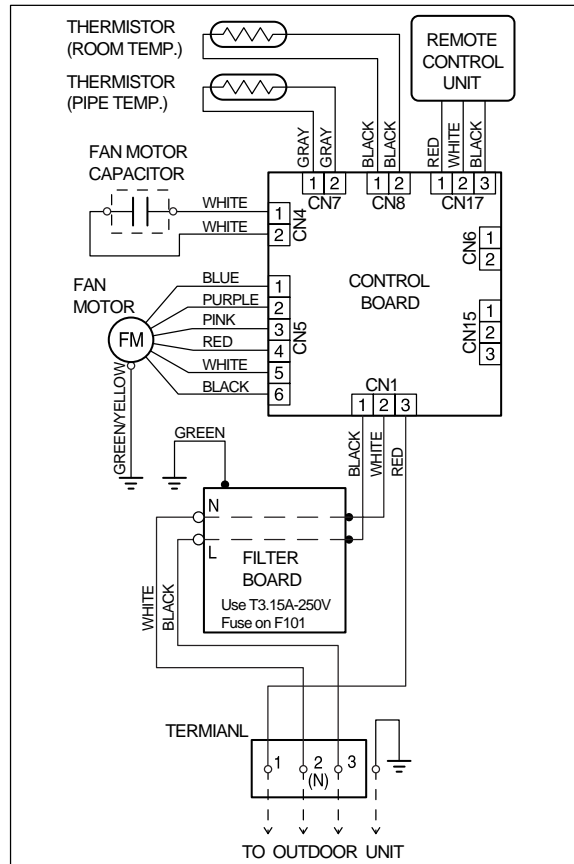

FAN MOTOR CAPACITOR	2.3 $\mu$ F
---------------------	-------------

OUTDOOR UNIT

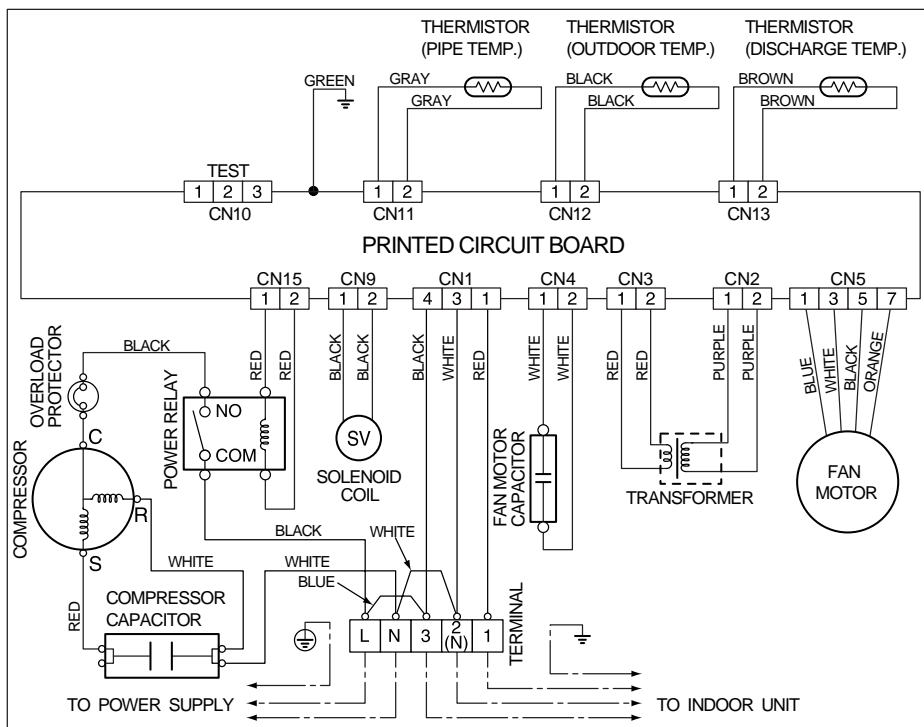

COMPRESSOR CAPACITOR	30 $\mu$ F
FAN MOTOR CAPACITOR	1.6 $\mu$ F

# INDOOR PRINTED CIRCUIT BOARD CIRCUIT DIAGRAM

Model : RD-90EA

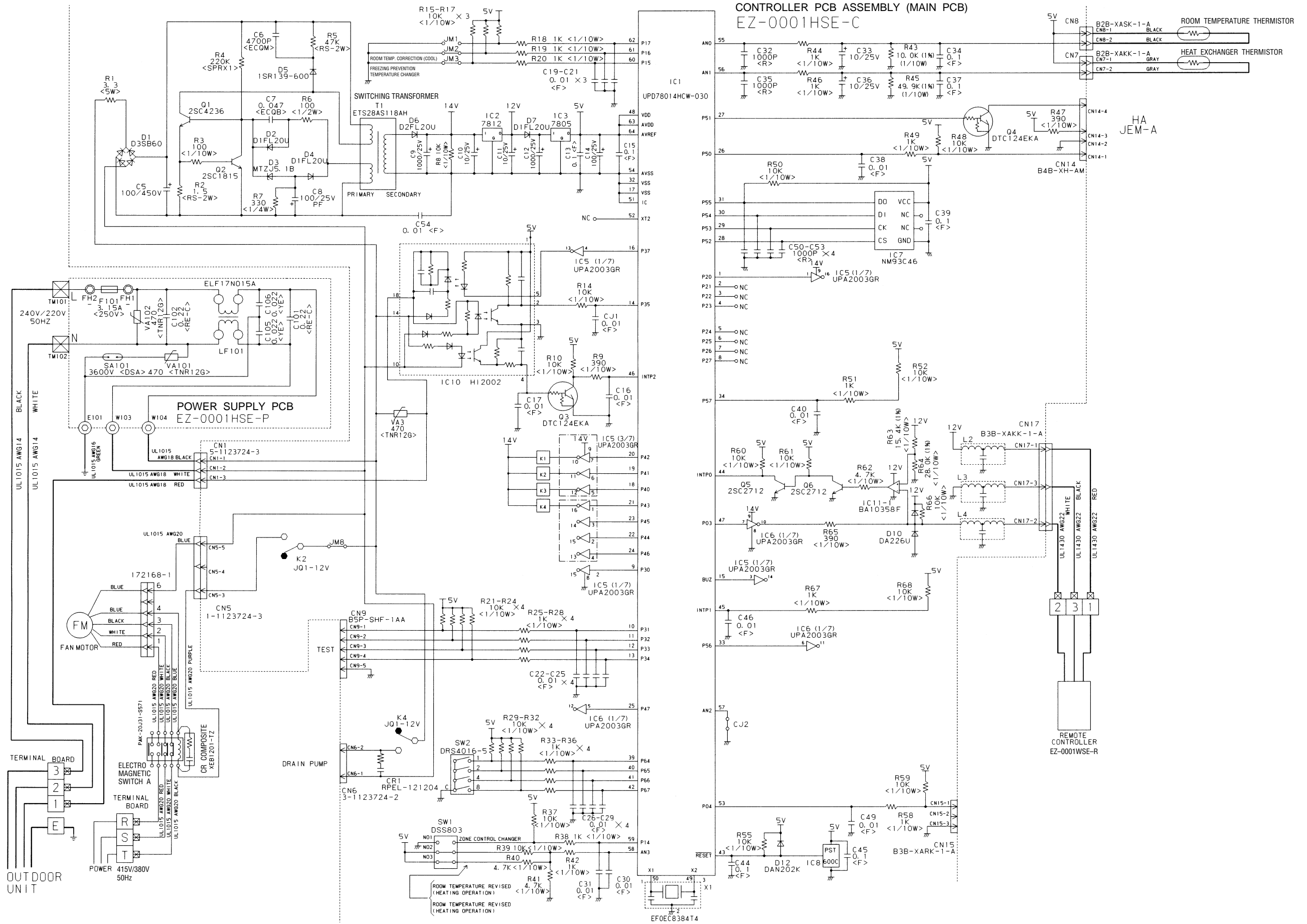

Model : RD-90TA

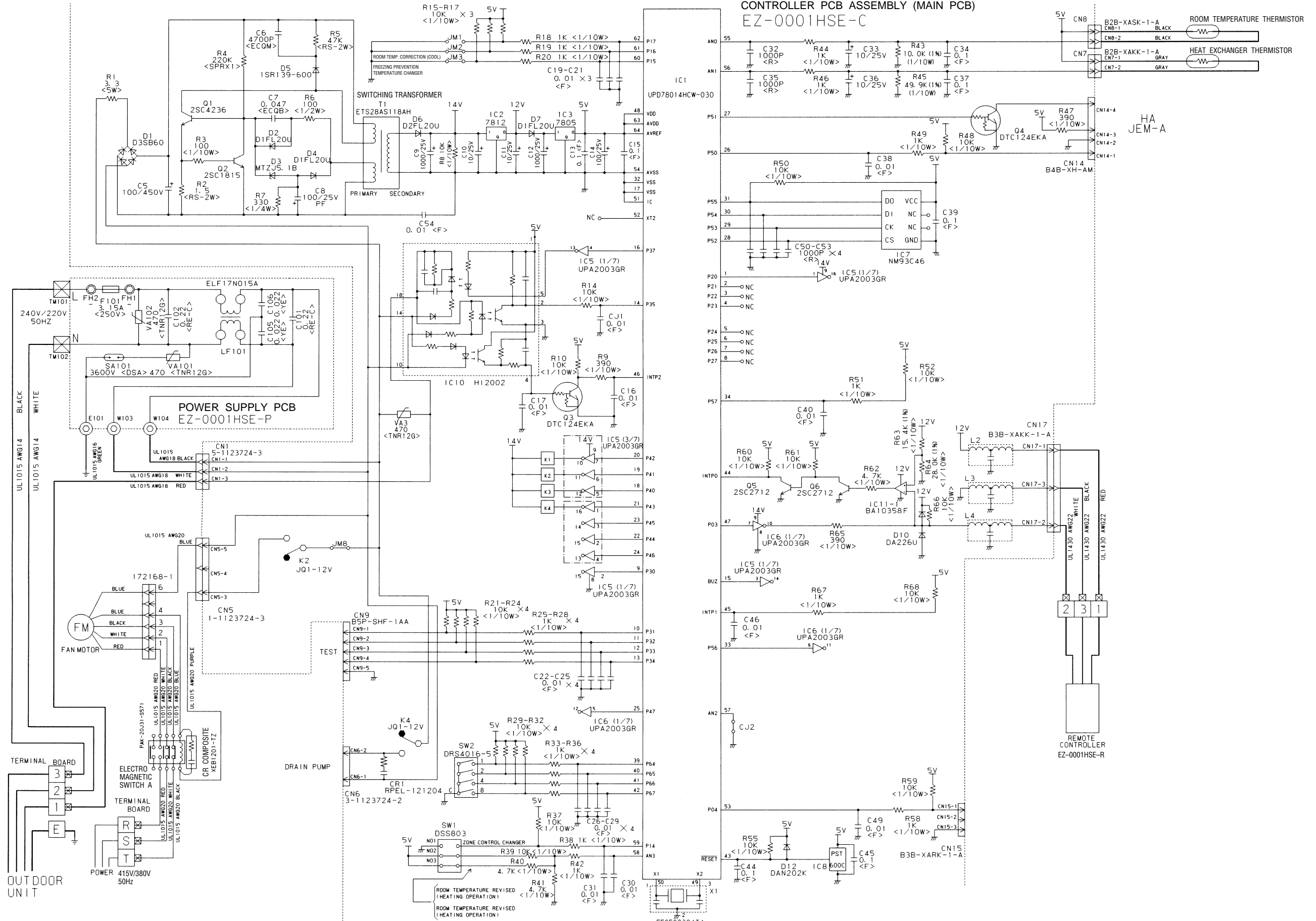



# OUTDOOR PRINTED CIRCUIT BOARD CIRCUIT DIAGRAM

Model : RO-90EPA

CONTROLLER PCB ASSEMBLY (MAIN PCB)

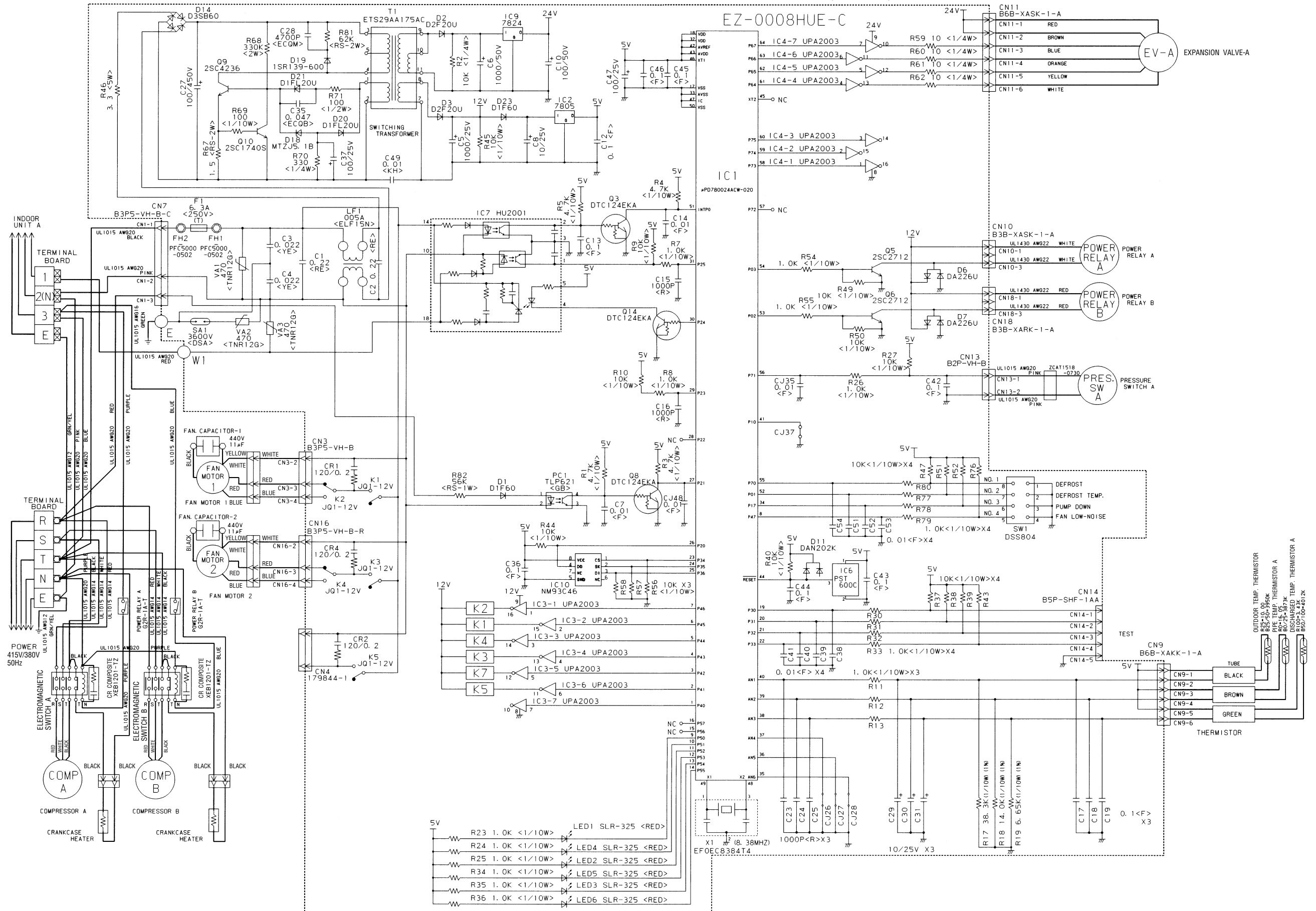

Model : RO-90TPA

CONTROLLER PCB ASSEMBLY (MAIN PCB)

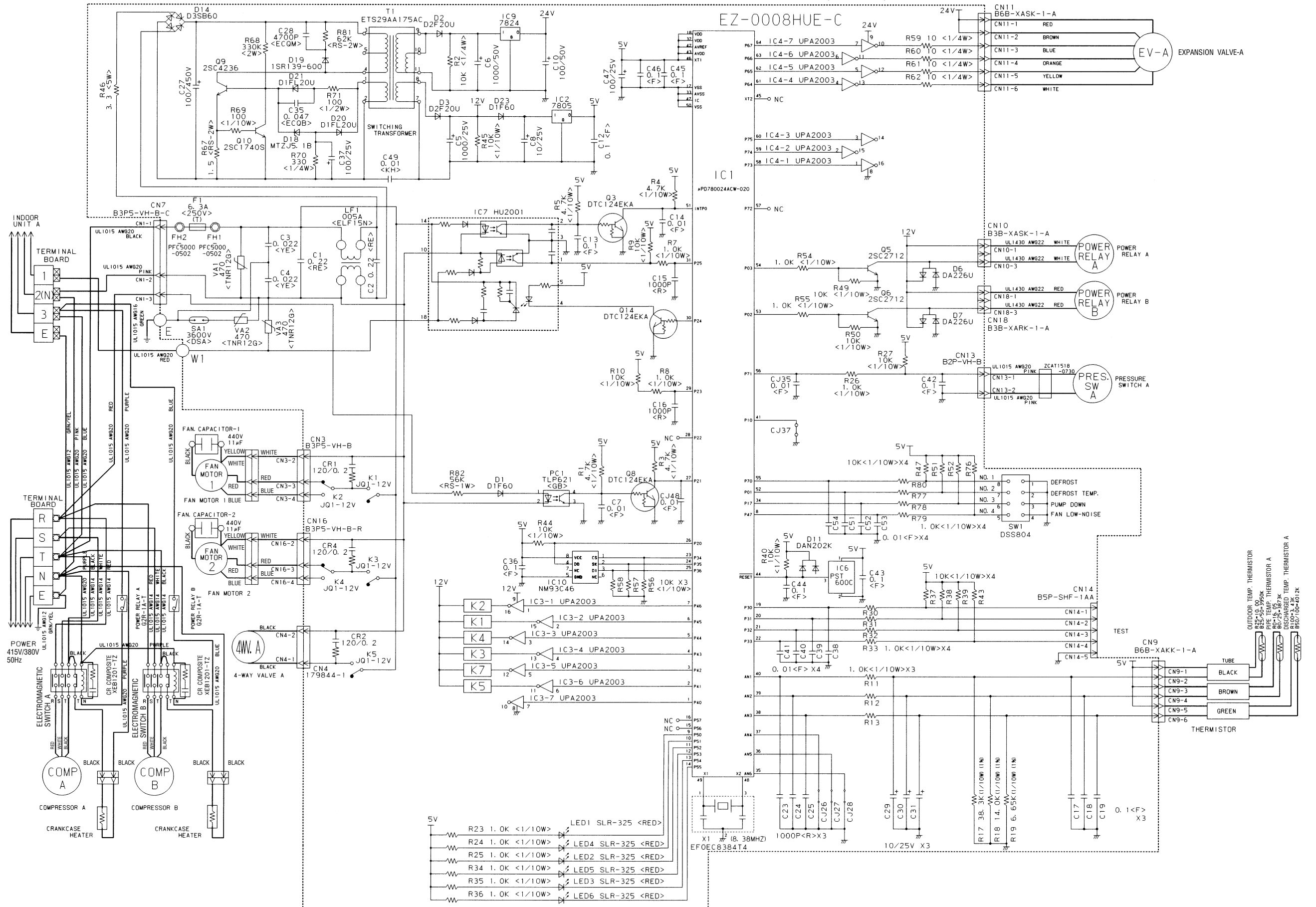

# DISASSEMBLY ILLUSTRATION

Model : ROD-9AA

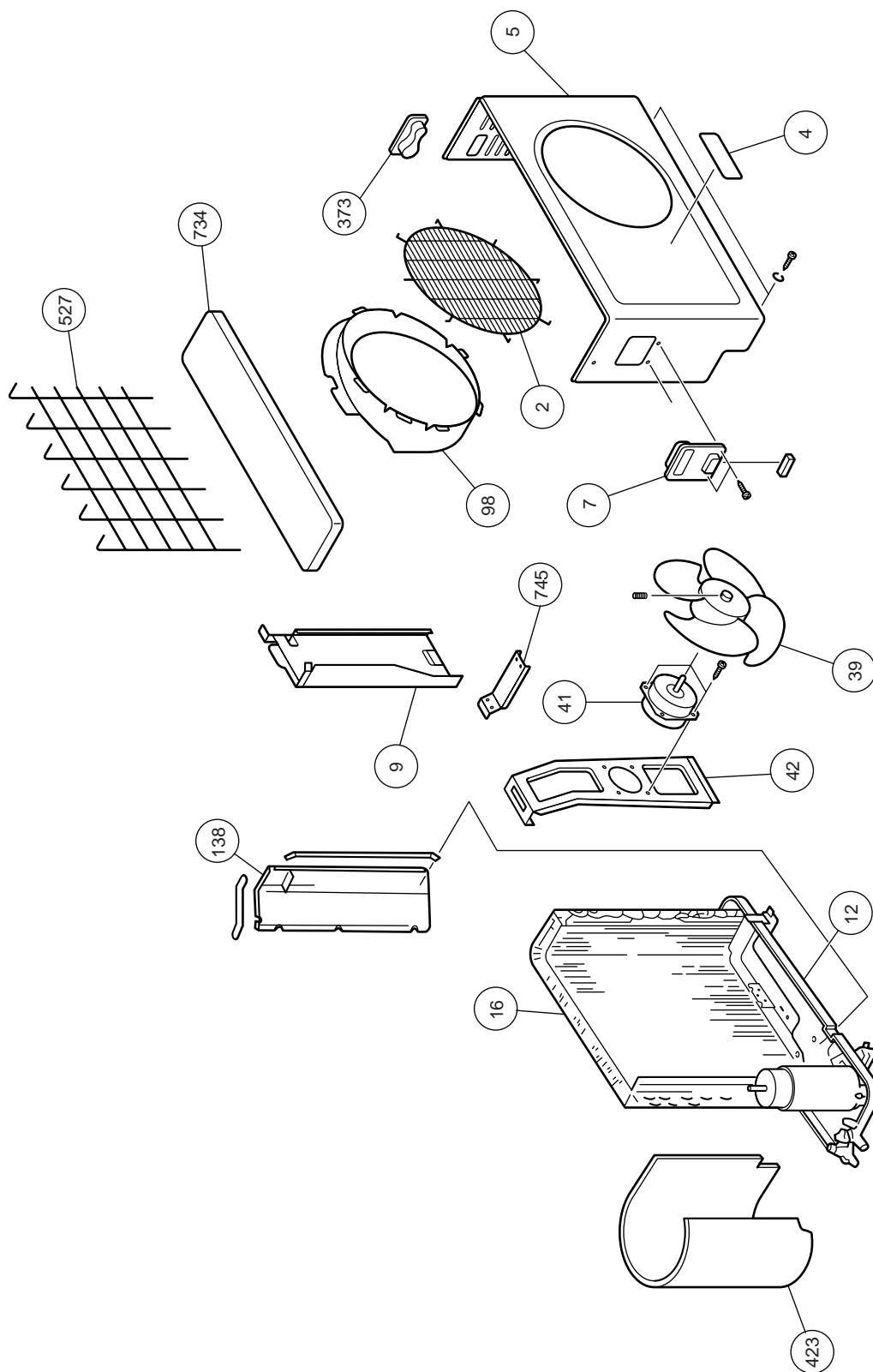

Model : ROD-9AA

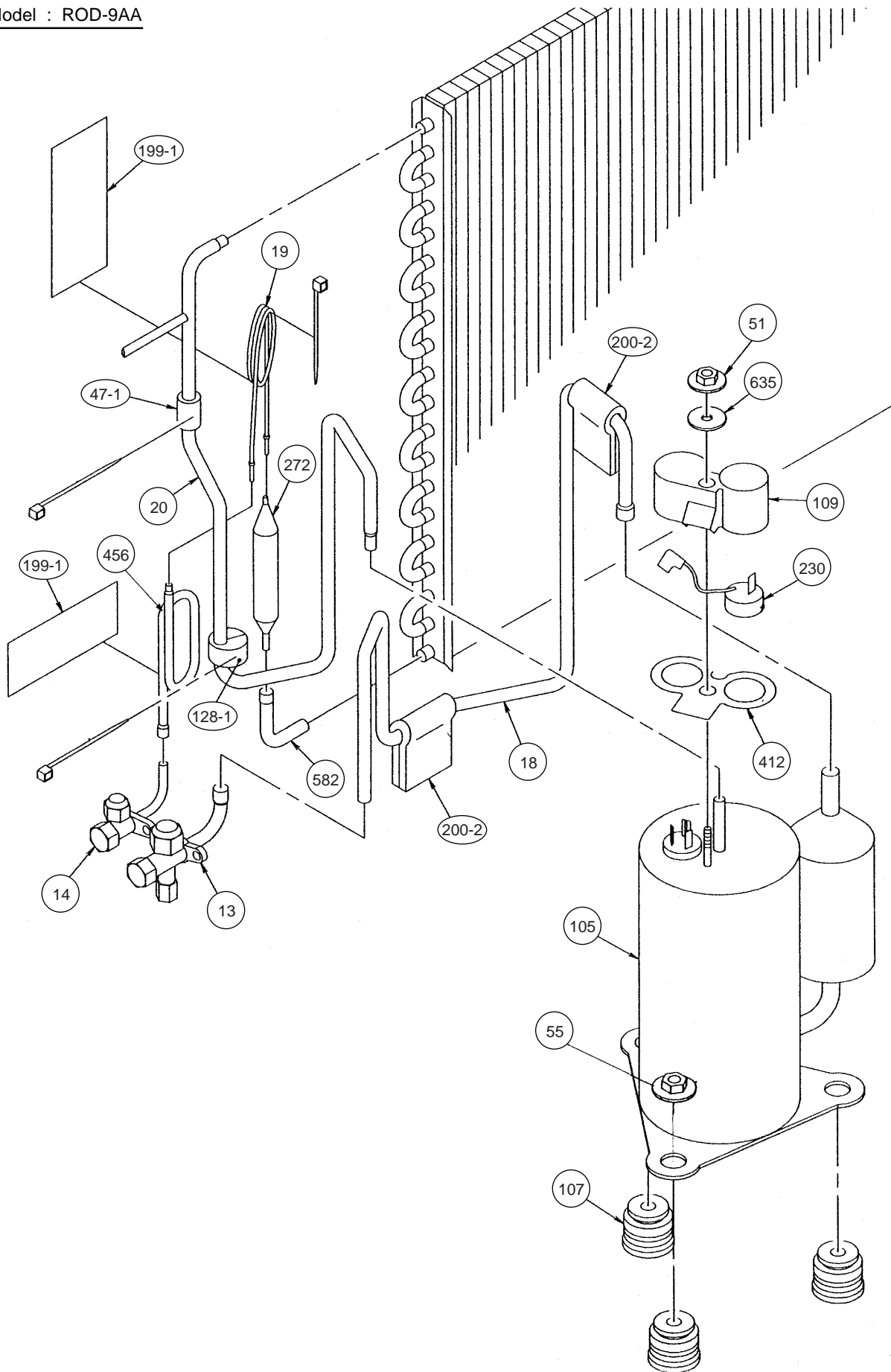

Model : ROD-9AA

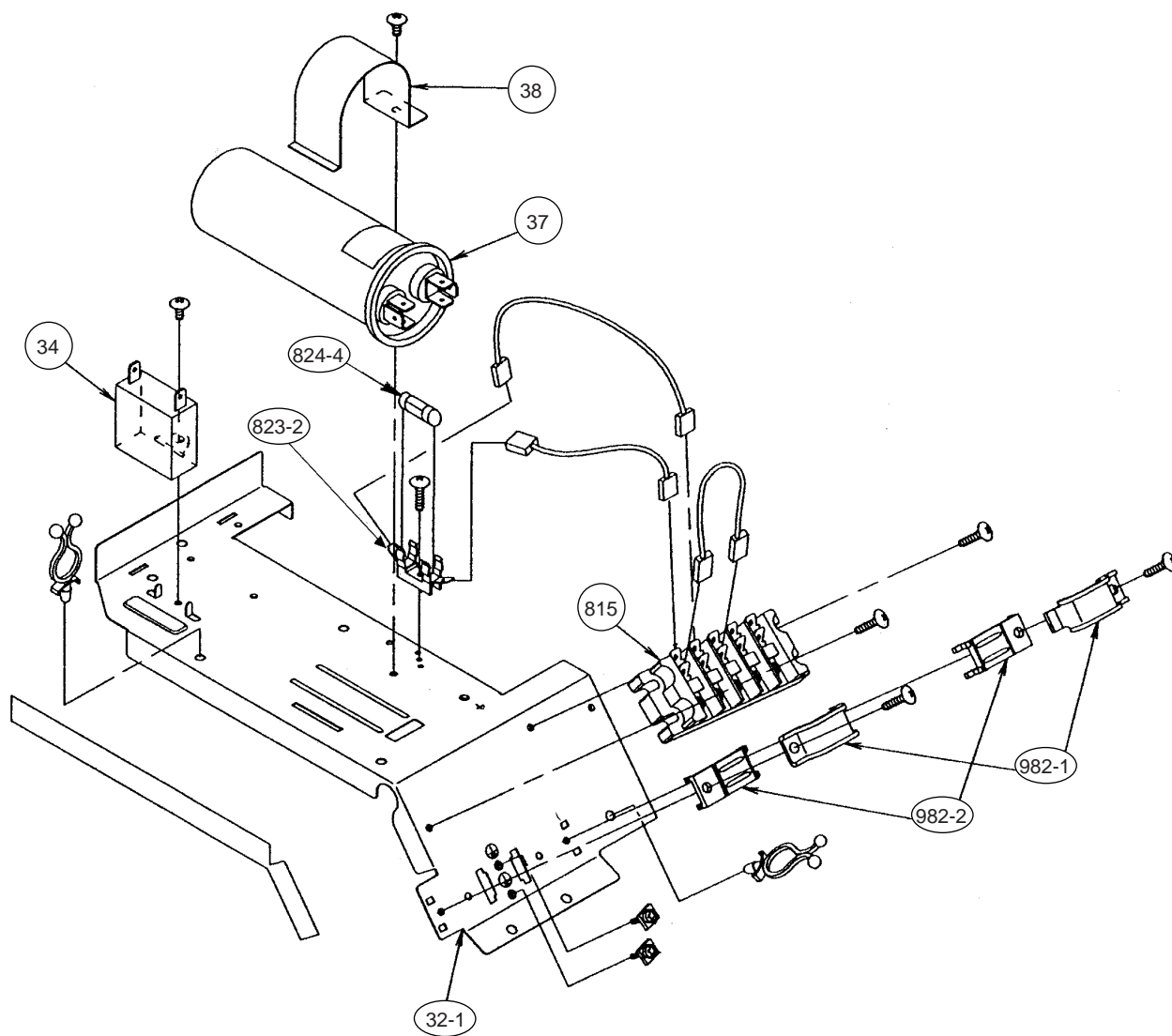

Model : ROD-9RA

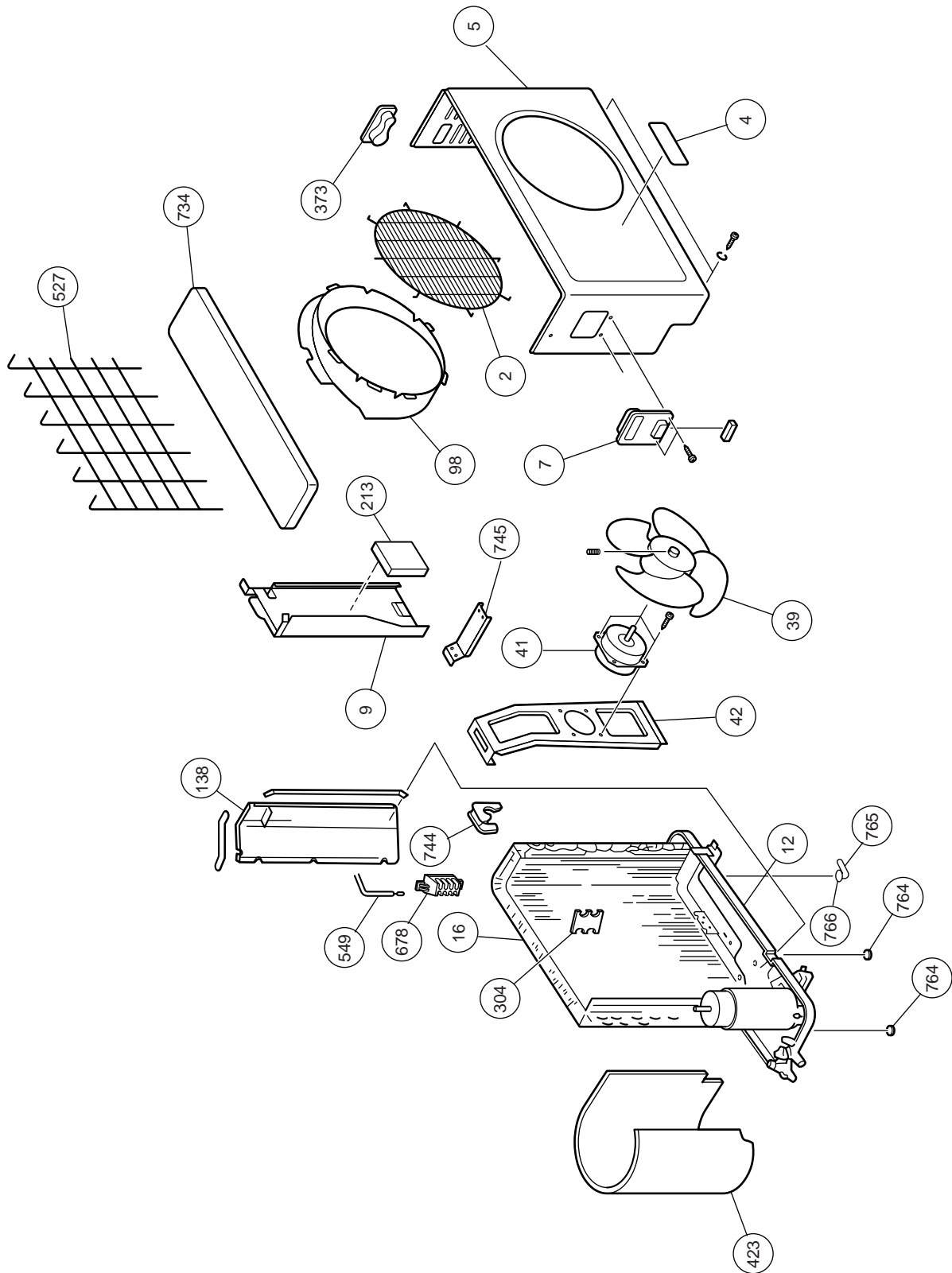

Model : ROD-9RA

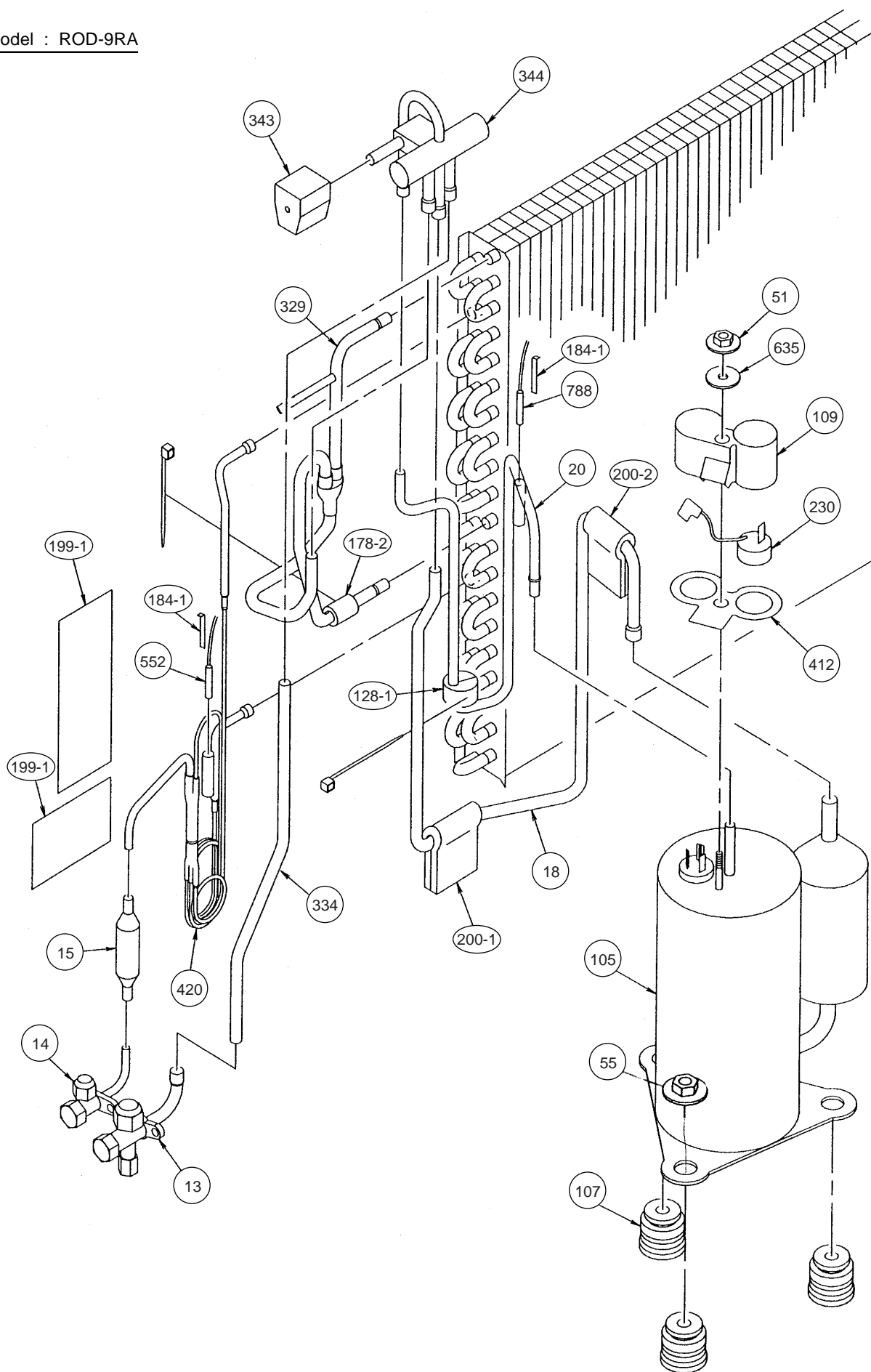

Model : ROD-9RA

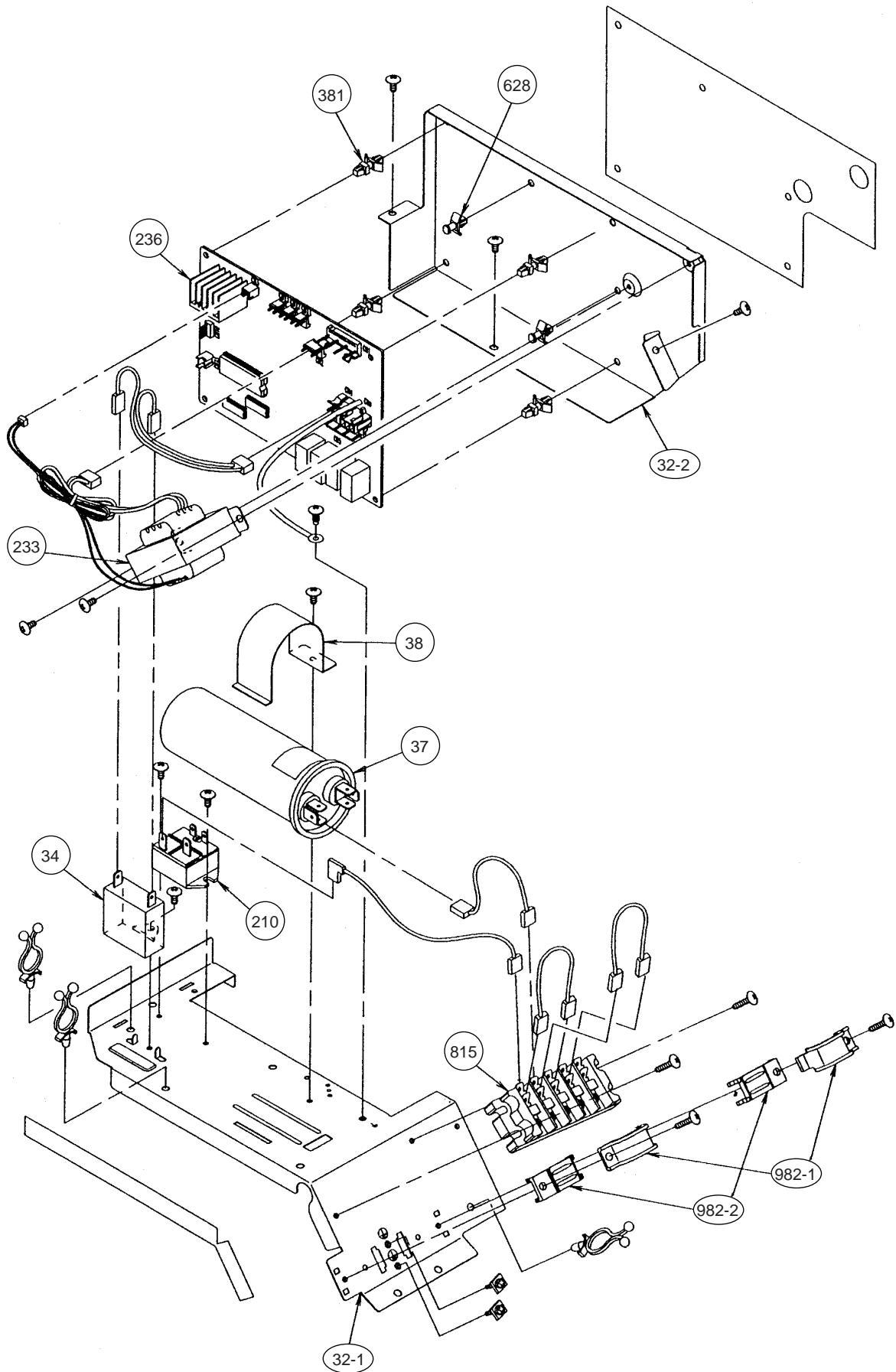



Models : RD-9AA, RD-9RA

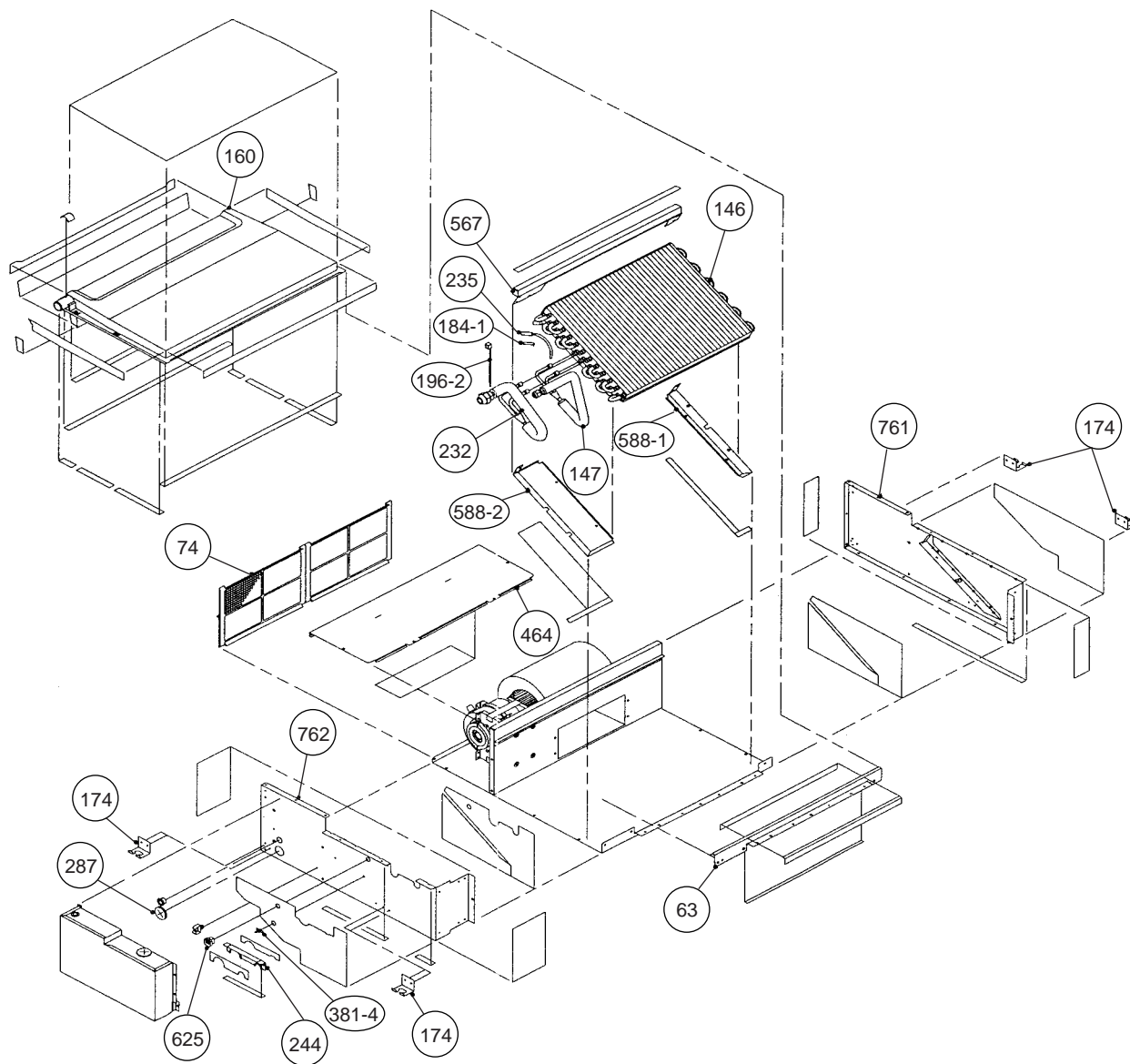

Models : RD-9AA, RD-9RA

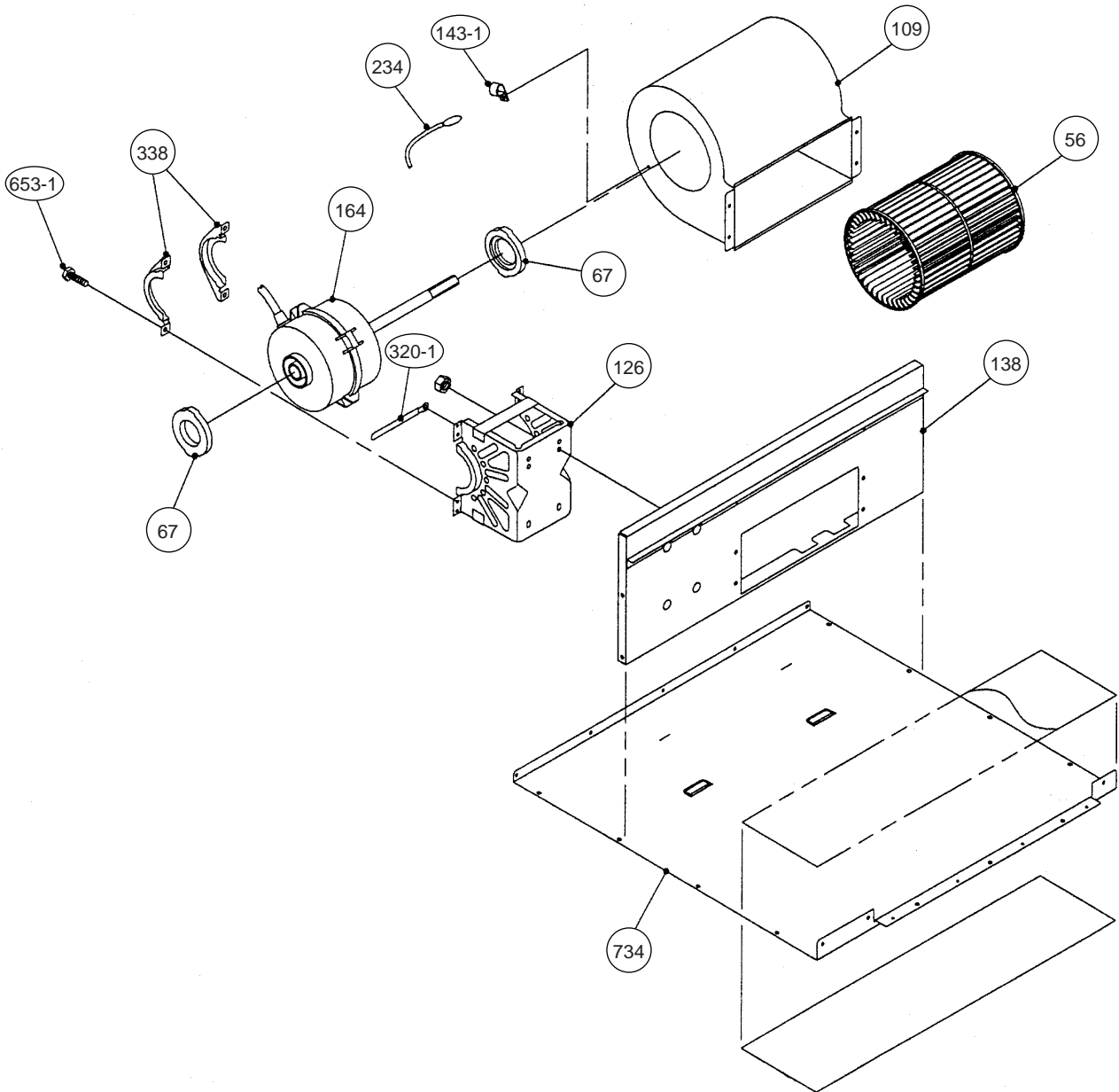

Model : RD-9AA

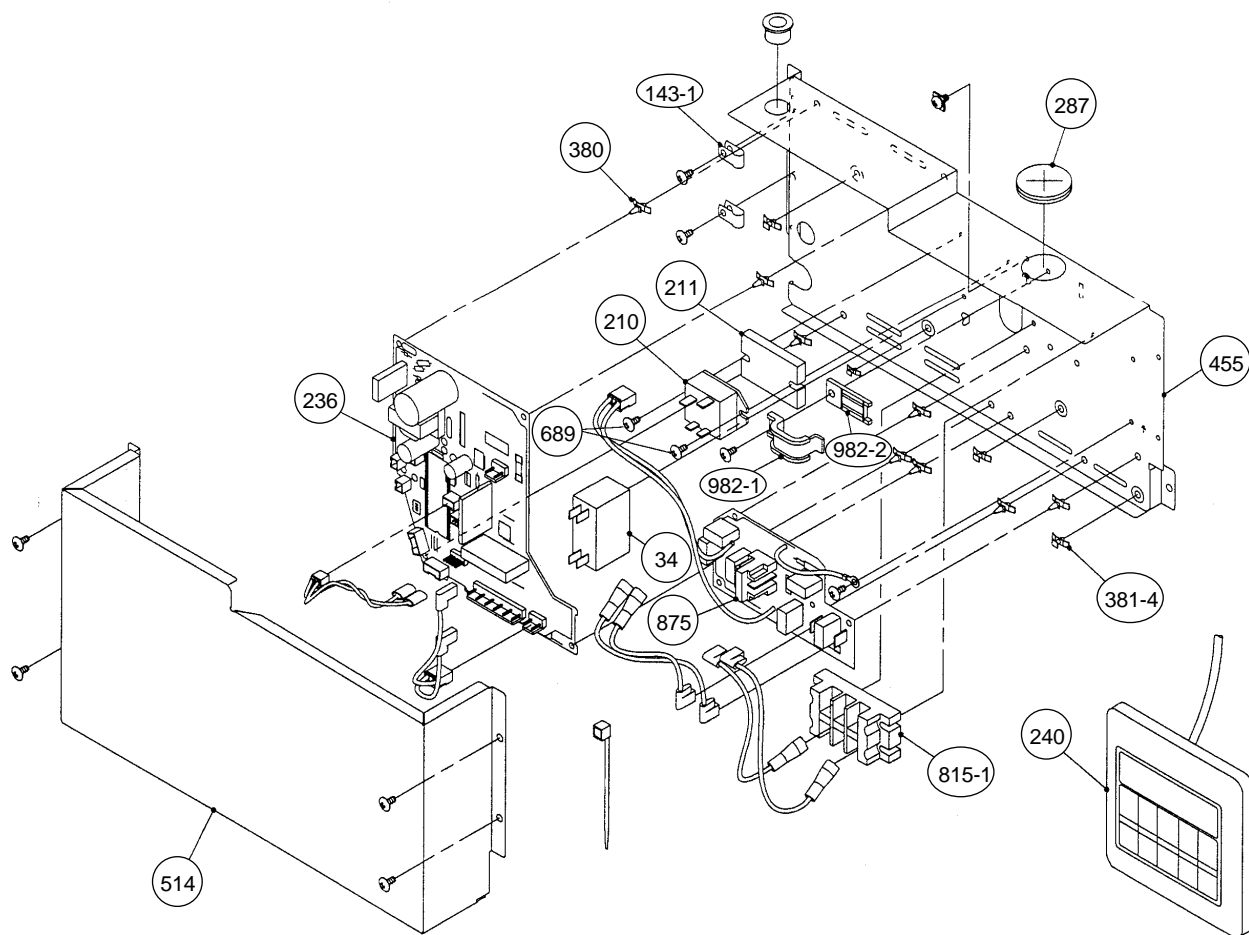

Model : RD-9RA

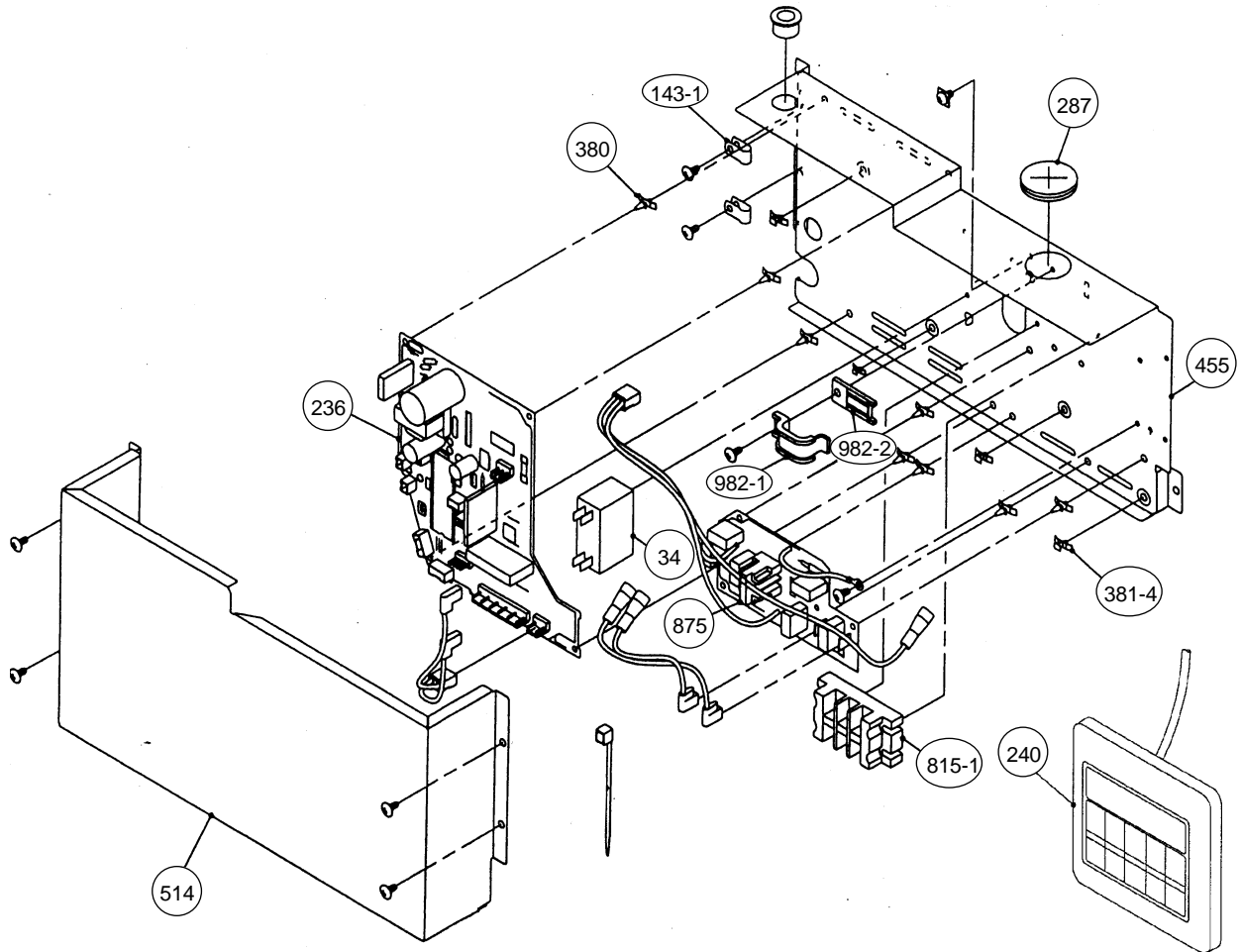

# PARTS LIST

When you order parts, please make a photocopy of this page and fill the number of the parts in the "Order" column.

## INDOOR UNIT

Ref. No.	Description	Part No.		Ord. Q'ty	Ref. No.	Description	Part No.		Ord. Q'ty
		RD-9AA	RD-9RA				RD-9AA	RD-9RA	
34	Capacitor(Fan Motor)	9357965017	9357965017		244	Cover(Piping)	9363330007	9363330007	
56	Sirocco Fan Assy	9358621004	9358621004		287	Cap(Power)	9352173011	9352173011	
63	Panel Assy Front	9363722000	9363722000		320-1	Wire Clamp Metal	313483219905	313483219905	
67	Rubber(Vibration-proof)	313659068604	313659068604		338	Motor Fixture	9358594001	9358594001	
74	Filter	9363326000	9363326000		380	Locking Spacer	313209391403	313209391403	
109	Casing Assy	9363322002	9363322002		381-4	Locking Spacer	0600118075	0600118075	
126	Motor Fixing Table Assy	9358591000	9358591000		455	Control Box	9363200003	9363200003	
138	Separate Wall	9363193008	9363193008		464	Cover(Cabinet)	9363325003	9363325003	
143-1	Clamp NK-3N	313361274700	313361274700		514	Control Box Cover	9363201000	9363201000	
146	Evaporator Assy	9364456027	9364456027		567	Support Plate (Eva.)	9363323009	9363323009	
147	Inlet Pipe(Eva.) Assy	9363373004	9363373004		588-1	Bracket Eva. R	9363199000	9363199000	
160	Drain Pan	9363324006	9363324006		588-2	Bracket Eva. L	9363198003	9363198003	
164	Fan Motor Assy	9600778074	9600778074		625	Cord Bushing	9359240006	9359240006	
174	Hanger Bracket-L	9363195002	9363195002		653-1	Bolt (Fan Motor Fixing)	0700156014	0700156014	
184-1	Thermo. Spring-A	313728262708	313728262708		689	Screw Grip Tapping	9357837000	—	
196-2	Clamp SKB-150	313035356905	313035356905		734	Panel Top	9363408003	9363408003	
210	Main Relay	9356781007	—		762	Panel Side Assy(L)	9363409000	9363409000	
211	Cushion Rubber	313806328306	—		761	Panel Side Assy(R)	9363411003	9363411003	
232	Outlet Pipe(Eva.) Assy	9363387001	9363387001		815-1	Terminal-3P	9356488005	9356488005	
234	Thermistor Assy-Room	9703299063	9703299063		875	Filter PCB Assy	9703611018	9703583018	
235	Thermistor Assy-Pipe	9703297052	9703297052		982-1	Cord Clamp	9356857009	9356857009	
236	Controller PCB Assy	9703582035	9703582028		982-2	Cord Clamp-B	9356858006	9356858006	
240	Remote Control Unit	9701673056	9701673049						

## OUTDOOR UNIT

Ref. No.	Description	Part No.		Ord. Q'ty	Ref. No.	Description	Part No.		Ord. Q'ty
		ROD-9AA	ROD-9RA				ROD-9AA	ROD-9RA	
2	Fan Cover	9304109006	9304109006		213	Noise Insulation	—	313584258005	
4	Emblem-Rear	9361328006	9361328006		230	Overload Relay	9359927013	9359927013	
5	Cabinet-A, Painted	9302936017	9302936017		233	Power Transformer	—	9701549016	
7	Connector Cover	9357970004	9357970004		236	Controller PCB Assy	—	9703572012	
9	Cabinet-B, Painted	9302935010	9303744017		272	Strainer	9357309002	—	
12	Base Assy, Painted	9354493032	9354493032		304	Thermostat Fixture-B	—	313349051500	
13	3-Way Valve	9356494006	9356494006		329	Joint Pipe Assy	—	9364458007	
14	2-Way Valve	9364615004	9364615004		334	Suction Pipe-B	—	9351186012	
15	Dryer	—	313523082505		343	Solenoid Coil	—	9359616122	
16	Condenser Assy	9354494015	9364547008		344	4-Way Valve	—	313947302811	
18	Suction Pipe	9364486000	9363474008		373	Grip	313166178700	313166178700	
19	Capillary Tube	9365091005	—		381	Locking Spacer	—	313209391506	
20	Discharge Pipe Assy	9364484006	9364538006		412	Terminal Gasket	9362004008	9362004008	
32-1	Control Box Metal-A	9363406009	9363406009		420	Capillary Assy	—	9363412000	
32-2	Control Box Metal-B	—	9363407006		423	Noise Insulation-F	9350944019	9350944019	
34	Capacitor (Fan Motor)	9700468080	9700468080		456	Pipe-A	9352267017	—	
37	Running Capacitor	9356386066	9356386066		527	Protection Net	9355434003	9355444002	
38	Capacitor Clamp	313468061808	313468061808		549	Thermistor Assy-Outer	—	9357328027	
39	Propeller Fan Assy	9351589011	9351589011		552	Thermistor Assy	—	9701330034	
41	Fan Motor Assy-Out	9600649060	9600649107		582	Discharge Pipe-F	9301425017	—	
42	Bracket(Motor)	313166243804	313166243804		628	Locking Spacer-B	—	313005446558	
47-1	Rubber (Discha.Pipe)	313194159807	—		635	Terminal Washer	9359428015	9359428015	
51	Special Nut	9359430018	9359430018		678	Bracket(Thermistor)	—	313557406106	
55	Special Nut M8(For Comp.)	9355091008	9355091008		734	Cabinet Top Plate	9302937014	9302937014	
98	Fan Ring	313166296109	313166296109		744	Clamp (Condenser)	—	313166374106	
105	Compressor Assy	9364555003	9364555003		745	Motor Support	313166036308	313166036308	
107	Rubber Seat-A(For Comp.)	9359425014	9359425014		764	Drain Cap	—	313166024302	
109	Terminal Cover(For Comp.)	9363263008	9363263008		765	Drain Pipe(L-Type)	—	9301102000	
128-1	Rubber (Discharge Pipe)	313155086308	313155086308		766	Drain Pipe Packing	—	9301143003	
138	Separate Wall	9300672016	9303729014		788	Thermistor-Discharge	—	9358337011	
178-2	Capillary Holder Rubber	—	313394274808		815	Terminal-5P	9356497021	9356497021	
184-1	Thermo. Spring-A	—	313728262708		823-2	Fuse Holder	0500063024	—	
199-1	BR Sheet	313612108209	313612108209		824-4	Fuse	0600222529	—	
200-1	BR Sheet-B	—	9351990022		982-1	Cord Clamp	9356857009	9356857009	
200-2	BR Sheet-B	9351990039	9351990039		982-2	Cord Clamp-C	9359677000	9359677000	
210	Main Relay	—	9356781007						

[INDOOR UNIT]

CONTROLLER PCB ASSEMBLY (Ref. No.236)

( ) : Reverse cycle model only

When you order parts, please make a photocopy of this page

and fill the number of the parts in the "Order" column.

Ref. No.	Description	Part No.	Ord. Qty	Ref. No.	Description	Part No.	Ord. Qty
IC1	IC $\mu$ PD 78014HCW-027	9703514012		R63	Res. 1/10W 15.4k $\Omega$ $\pm$ 1%	0200279565	
IC2	IC NJM 7812FA	0100462104		R64	Res. 1/10W 28k $\Omega$ $\pm$ 1%	0201114445	
IC3	IC NJM 7805FA	0100462081		C5	Cap, Elec. 450V 100 $\mu$ F	0300256060	
IC5,6	Xstr Array $\mu$ PA 2003GR E2	0100028041		C6	Cap, Plastic. 4700pF	0300269091	
IC7	IC BR 93LC46RF-E2	0100295016		C7	Cap, Plastic. 50V 0.047 $\mu$ F	0300169339	
IC8	IC PST 600CMT R	0101461120		C8	Cap, Elec. 25V 100 $\mu$ F	0301197560	
IC9	Photocoupler TLP621(D4)-GB	0000117074		C9	Cap, Elec. 25V 1000 $\mu$ F	0301196495	
(IC10)	IC HI2002	9701384020		C10,11,33,36	Cap, Elec. 25V 10 $\mu$ F	0301192312	
IC11	IC BA10358FE2	0101846071		C12	Cap, Elec. 25V 1000 $\mu$ F	0301158264	
Q1	Xstr 2SC4236	0000164047		C13,15,34,37,39,44,45	Cap, Ceramic 50V 0.1 $\mu$ F	0300311752	
Q2	Xstr 2SC1815	0000002011		C14	Cap, Elec. 25V 100 $\mu$ F	0301192350	
Q3,4	Xstr DTC124EKA	0000936033		C16,17-31,38,40,46,49,CJ1	Cap, Ceramic 50V 0.01 $\mu$ F	0300311738	
Q5,6	Xstr 2SC2712	0000781053		C32,35,50-53	Cap, Ceramic 50V 1000pF	0300308509	
D1	Diode D3SB60	0000689045		C54	Cap, Ceramic 0.01 $\mu$ F	0300209127	
D2,4,7	Diode D1FL20U	0000746519		(VA3)	Varistor TNR12G471K	0000038010	
D3	Diode MTZJ5.1B	0000852166		SSR1	Relay G3M-202P-UTU	9701829019	
D5	Diode 1SR139-600	0000353120		K1,2,3,4	Relay JQ1-12V	9701316014	
D6	Diode D2FL20U	0000906500		CR1	Network RPEL-121204 -C	9701125012	
D8	Diode D1F60	0000208024		SW1	Switch, Side DSS803	9701392018	
D9,10	Diode DA226U	0000625036		SW2	Switch, Rotary DRS4016-5	9701694013	
D12	Diode DAN202K	0000684019		T1	Power Transformer ETS28AS118AH	9702727017	
R1	Res. Cement 5W 3.3 $\Omega$ $\pm$ 10%	0200153148		X1	Ceramic Resonator EF0EC8384T4	9701261017	
R2	Res. Metal 2W 1.5 $\Omega$ $\pm$ 5%	0201107119		L2-4	EMI Filter EXCEMT103DT	0400406396	
R3	Res. 1/10W 100 $\Omega$ $\pm$ 5%	0200212500		CJ1,2	Res. 0 $\Omega$	0200212012	
R4	Res. Carbon 220k $\Omega$ $\pm$ 5%	0200111353		JM2-4,6	Wire 0.6dia. L=10mm	9700025016	
R5	Res. Metal 2W 47k $\Omega$ $\pm$ 5%	0201107652		JM9	Res. 0 $\Omega$	0200230016	
R6	Res. 1/2W 100 $\Omega$ $\pm$ 5%	0200731506		CN1	Plug, PCB 5-1123724-2	0501321574	
R7	Res. 1/4W 330 $\Omega$ $\pm$ 5%	0200708621		(CN1)	Plug, PCB 5-1123724-3	0501321635	
R8,10,13-17,21-24,29-32,37,39,48,50,52,55,59,60,61,66,68	Res. 1/10W 10k $\Omega$ $\pm$ 5%	0200213019		CN4	Plug, PCB 2-1123724-2	0501321529	
R9,47,65	Res. 1/10W 390 $\Omega$ $\pm$ 5%	0200212647		CN5	Plug, PCB 5430C063	0500957026	
R11	Res. Metal 1W 56k $\Omega$ $\pm$ 5%	0201106662		CN6	Plug, PCB 3-1123724-2	0501321536	
R12,18-20,25-28,33-36,38,42,44,46,49,51,58,67	Res. 1/10W 1k $\Omega$ $\pm$ 5%	0200212746		CN7	Plug, PCB B2B-XAKK-1-A	0501045227	
R40,41,62	Res. 1/10W 4.7k $\Omega$ $\pm$ 5%	0200212906		CN8	Plug, PCB B2B-XASK-1-A	0501045012	
R43	Res. 1/10W 10k $\Omega$ $\pm$ 1%	0200279497		CN9	Plug, PCB B5P-SHF-1AA	0500006069	
R45	Res. 1/10W 49.9k $\Omega$ $\pm$ 1%	0200279824		CN12	Plug, PCB B3B-XASK-1-A	0501045029	
				CN14	Plug, PCB B4B-XH-AM	0500005314	
				CN15	Plug, PCB B3B-XARK-1-A	0501045319	
				CN17	Plug, PCB B3B-XAKK-1-A	0501045357	

FILTER PCB ASSEMBLY (Ref. No.875)













Ref. No.	Description	Part No.	Ord. Qty	Ref. No.	Description	Part No.	Ord. Qty
C101,102	Cap. Plastic 0.22 $\mu$ F	0300304099		LF101	EMI Filter ELF17N015A	0400197119	
C105,106	Cap. Plastic 0.022 $\mu$ F	0301052098		F101	Fuse 2183.15	0600285210	
SA101	Arrester DSA-362MA-05	0600168032		FH1,2	Fuse Holder PFC5000-0502	0500158072	
VA101,102	Varistor TNR12G471K	0000038010		E101	Wire w/Terminal L=100 GRN	9702313012	
TM101,102	Plug Contact 86028	0500536016		W103,104	Wire AWG18 2P	9702419035	
				(W103,104)	Wire AWG18 3P	9702310059	

[OUTDOOR UNIT]





CONTROLLER PCB ASSEMBLY (Ref. No.236)

Ref. No.	Description	Part No.	Ord. Qty	Ref. No.	Description	Part No.	Ord. Qty
IC1	IC $\mu$ PD78081CU-011	9701721016		C9-11,14-16,30	Cap, Ceramic 50V 0.01 $\mu$ F	0300013113	
IC2	IC HU2001	9701651016		C17	Cap, Elec. 25V 100 $\mu$ F	0300051375	
IC3	IC PST600D-2-TP	0101461113		C20,23,26,35	Cap, Ceramic 50V 1000pF	0300011096	
IC4	IC NJM 7805FA	0100462081		C33	Cap, Elec. 25V 2200 $\mu$ F	0300915417	
IC5,6	IC BA12003	0101650012		F1	Fuse 2183.15	0600285210	
Q1	Xstr 2SD880	0000001014		FH1,2	Fuse Holder PFC5000-0502	0500158072	
Q2,3	Xstr DTC124ES	0000517010		SA1	Arrester DSA-362MA-05	0600168032	
D1	Diode D2SB20	0000599023		K1-3	Relay JQ1-12V	9701316014	
D2	Diode MTZJ15C	0000852203		CR1,3	Network RPEL-121204 -C	9701125012	
D3-D5	Diode 1SR139-400	0000353137		L1	EMI Filter SU16VF-15030	0400134114	
D6	Diode 1SS133	0000572019		VA1,4	Varistor TNR12G471K	0000038010	
LED1,2	Diode SLR-325VC	0000813259		HT1	Heat Sink PUG 26-25	9701428014	
RC1	RC Module ARCL14FS103J102J103M	0200301020		X1	Ceramic Resonator EF0EC5004T4Z	9701261024	
R1,2	Res. Carbon 5.6k $\Omega$ $\pm$ 5%	0200994192		CN1	Plug, PCB 53406-9110	0500951086	
R3,6,10-12,14,16,18,20,24	Res. Carbon 1k $\Omega$ $\pm$ 5%	0200994017		CN2	Plug, PCB B2P3-VH-B-R	0500011766	
R4,26	Res. Carbon 4.7k $\Omega$ $\pm$ 5%	0200994178		CN3	Plug, PCB B2B-XH-AM	0500005321	
R5,7-9,13,21-23,25	Res. Carbon 10k $\Omega$ $\pm$ 5%	0200994253		CN4	Plug, PCB 53331-0210	0501033019	
R15,17	Res. Metal 14k $\Omega$ $\pm$ 5%	0201028612		CN5	Plug, PCB B4P7-VH-B	0500011742	
R19	Res. Metal 6.65k $\Omega$ $\pm$ 5%	0201028766		CN9	Plug, PCB 179844-1	0501121013	
C1,4	Cap, Plastic. 0.1 $\mu$ F	0300894835		CN10	Plug, PCB B4P-SHF-1AA	0500006038	
C2,3	Cap, Ceramic 4700pF	0300727546		CN11	Plug, PCB B2P-VH-B	0500011124	
C5	Cap, Elec. 50V 2200 $\mu$ F	0301206026		CN12	Plug, PCB B2P-VH-B-C	0500011568	
C6,7,21,24,27	Cap, Elec. 25V 10 $\mu$ F	0300004258		CN13	Plug, PCB B2P-VH-B-R	0500011148	
C8,18,19,22,25,28,29,34,36	Cap, Ceramic 0.1 $\mu$ F	0300988251		CN15	Plug, PCB B2B-XASK-1-A	0501045012	
				E	Wire w/Terminal L=210 GRN	9701325016	

### INDOOR UNIT ACCESSORIES

Name and Shape	Q'ty	Application	RD-9AA	RD-9RA
Installation template 	1	For positioning the indoor unit	9364224008	9364224008
Hook metal 	4	For suspending the indoor unit from ceiling	9363195002	9363195002
Tapping screw (φ 4 x 10) 	8	For installing the hanger	301171164104	301171164104
Special nut A (large flange) 	4	For suspending the indoor unit from ceiling	313005446653	313005446653
Special nut B (small flange) 	4		313005446759	313005446759
Coupler heat insulation (large) 	1	For indoor side pipe joint (large pipe)	9350716029	9350716029
Coupler heat insulation (small) 	1	For indoor side pipe joint (small pipe)	9352766015	9352766015
Binder 	1 (Small)	For remote control unit and remote control unit cord binding	313361275805	313361275805
	4 (Large)	For fixing the coupler heat insulation	312300787605	312300787605
Remote control unit 	1		9701673056	9701673049
Remote control unit cord clamp 	10	For installing the remote control unit cord	313714181904	313714181904
Tapping screw (flush heads) 	10	For installing the remote control unit cord clamp	301141153027	301141153027
Filter 	2		9363326000	9363326000
Drain hose insulation 	1	Insulates the drain hose and vinyl hose connection	313806217708	313806217708

### OUTDOOR UNIT ACCESSORIES

Name and Shape	Q'ty	Application	ROD-9AA	ROD-9RA
Hexagon wrench 	1	For vacuum	9351228019	9351228019
Drain pipe packing 	1	For outdoor unit drain piping work (May not be supplied, depending on the model)	—	9301143003
Drain pipe 	1		—	9301102000
Cap (drain) 	2		—	313166024302



MANUFACTURER :

**Fuji Denki Sosetsu Co., Ltd.**

Tokyo, Japan

0010J1755

October 2000 Printed in Japan



**Большая библиотека технической документации**

<https://splitsystema48.ru/instrukcii-po-ekspluatácii-kondicionerov.html>

**каталоги, инструкции, сервисные мануалы, схемы.**